

Instruction Manual, Operation and Maintenance
original instructions

DVC 800 AS

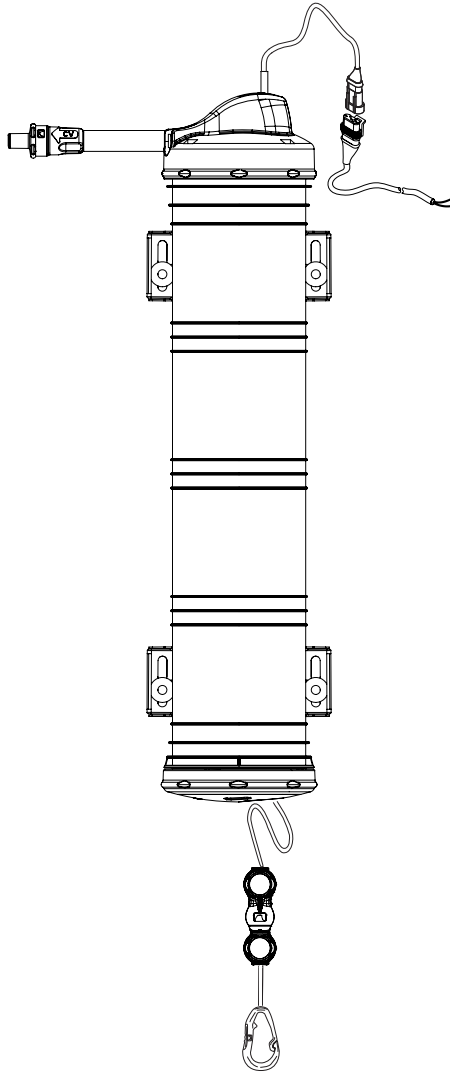

InterPuls

InterPuls S.p.A.
Via F. Maritano, 11 - 42020 - Albinea (RE) – ITALY
Tel. +39 0522 347511
Fax +39 0522 348516
sales@interpuls.com

MANUFACTURER	InterPuls S.p.A
ADDRESS	Via: F. Maritano, 11 Postal code: 42020 - Albinea (RE) - ITALY Tel.: +39 0522 347511 Telefax: +39 0522 348516 Website: www.milkrite-interpuls.com E-mail: sales@interpuls.com
TYPE OF DOCUMENT	Instruction, Use and Maintenance Manual
DOCUMENT CODE	5240007_EN
EDITION	06.17
PRODUCT	DVC 800 AS
YEAR OF MANUFACTURE	2017

InterPuls is a registered trade mark of InterPuls SpA.

The information contained in this document is not binding and can be modified without notice. References in this document to manufacturer trademarks are for identification only. Certain company and product names used throughout the document are trademarks of their respective owners.

Summary

DVC 800 AS	1
1 GENERAL INFORMATION	4
1.1 General information and safety warnings	4
1.1.1 Important warnings	4
1.1.2 Symbol used in this manual	4
1.1.3 Rules and regulations for the user	4
1.1.4 Limitation of liability	4
1.2 Prior using the product	4
1.2.1 Requirements and rules for personnel and Safety Rules	4
1.3 Disposal	5
1.3.1 General regulation	5
1.4 Fire prevention	5
1.4.1 Fire prevention	5
1.4.2 Safety regulations	5
1.4.3 Characteristic of extinguishers	5
2 DESCRIPTION OF THE PRODUCT	6
2.1 Intended use – Designated use	6
2.2 Operating principle	6
2.3 Main components	6
2.4 Optional components	6
2.5 Improper use	6
3 TECHNICAL FEATURES	7
4 INSTALLATION – OPERATING INSTRUCTIONS	8
5 MAINTENANCE	9
5.1 Introduction	9
5.2 Piston not sliding freely in cylinder	9
6 PRECAUTIONS FOR USE	10
7 TROUBLESHOOTING	11
8 EXPLODED DRAWING	14

1 GENERAL INFORMATION

1.1 General information and safety warnings

1.1.1 Important warnings

To safeguard the operator and prevent any damage to the equipment, before carrying out any kind of operation it is important to have read and fully understood the instruction manual.

1.1.2 Symbol used in this manual

The following symbols are used in this manual to highlight indications and warnings which are of particular importance:

**WARNING**

This symbol indicates health and safety regulations designed to protect operators and/or any exposed persons.

**CAUTION**

This symbol indicates that there is a risk of causing damage to the equipment and/or its components.

**NOTE**

This symbol is used to highlight useful information.

1.1.3 Rules and regulations for the user

**WARNING**

Any failure to observe the warnings provided in this manual may lead to equipment malfunctions or damage to the system.

1.1.4 Limitation of liability

InterPuls S.p.A. declines all liability for damage to persons, animals and/or things caused by incorrect use of the equipment.

1.2 Prior using the product

1.2.1 Requirements and rules for personnel and Safety Rules

**WARNING**

Before using the device, the operator must carefully read the manual.

this appliance can be used by person aged from 18 years and above and persons with reduced physical, sensory or mental capabilities or lack of experience and knowledge if they have been given supervision or instruction concerning use of the appliance in a safe way and understand the hazards involved

During the assembly and activation of the device, follow the instructions in the manual and rules and regulations applying to health and safety at the workplace.



WARNING

**Children shall not play with the appliance.
Cleaning and user maintenance shall not be made by children without supervision.**

1.3 Disposal

1.3.1 General regulation

The appliances must be disposed of only and exclusively by specially authorized waste disposal companies in accordance with all relative legislation and prescriptions.

The packaging must be consigned to the relative authorized companies to be recycled.

1.4 Fire prevention

1.4.1 Fire prevention



NOTE

The device is not equipped with fire extinguishers.

The operator must make sure that the place in which the appliance is installed is equipped with an adequate number of suitable fire extinguishers. The extinguishers must be positioned where they are clearly visible and protected from damage and improper use.

1.4.2 Safety regulations



WARNING

It is strictly prohibited to extinguish fires involving electrical equipment with water!

1.4.3 Characteristic of extinguishers

Use powder, foam or halogen extinguishers which must be positioned next to the device.

Operating personnel must receive adequate instruction on how to use the extinguishers.

2 DESCRIPTION OF THE PRODUCT

2.1 Intended use – Designated use

The device comprises a cylinder for the automatic detachment of milking clusters equipped with the AUTOSTART function.

2.2 Operating principle

The operator raises the milking cluster when it is in its detached position, leading to the immediate transmission of a signal to the control panel to activate milking mode with AUTOMATIC detachment.

Specifically, when the milking cluster is raised the control system performs the following operations:

- milking cluster release;
- shut-off valve opened;
- feeds pulsators (if pulsation is managed by the control system).

2.3 Main components

The cylinder is supplied with a valve designed to reduce speed of the cluster in the ascent phase (detachment), without negatively affecting the descent speed.

2.4 Optional components

The complete configuration can also include an additional valve (QVV: Quick Vent Valve – to be ordered separately) designed to speed up the release of the cluster during the attachment stage and make it unnecessary for the operator to exert traction to release it.

2.5 Improper use

The equipment described in this manual must not be used for purposes other than those for which it is designed and that are specified in the point entitled "Intended use – Designated use".







WARNING

All other uses outside the uses for which the equipment is designed and that are described in this manual are construed as "IMPROPER USE", in relation to which InterPuls S.p.A. declines all liability for any consequent injury to persons or animals or damage to the equipment.

3 TECHNICAL FEATURES

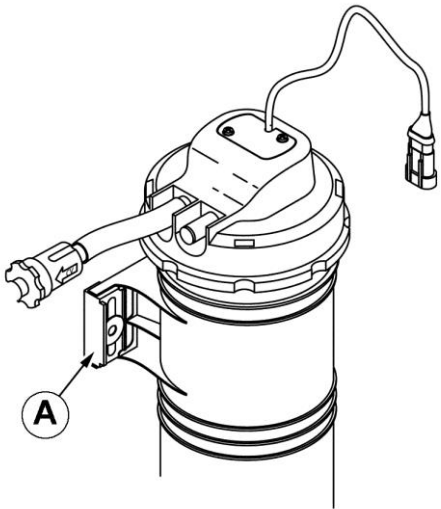
Model	DVC 800 AS
Operational vacuum	from 36 to 50 KPa
Pneumatic connection	To CV by means of 2 nipples with 7.1 mm inside diameter (10.4 mm outside diameter)
Electrical connection	To control panel by means of contact cable.
Dimensions	(WxLxH)= 130x120x512
Stroke	800 mm
Weight	1.1 kg
Mounting centre-distance	110x300mm
Fixing screw	M6

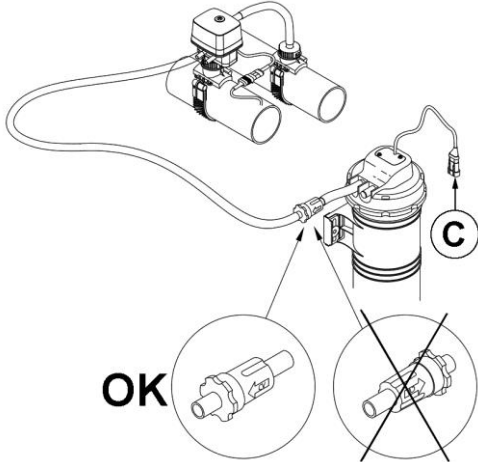
4 INSTALLATION – OPERATIN INSTRUCTIONS

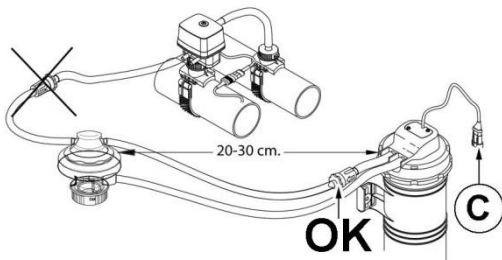
Step	Description	
1	<p>Mount the cylinder by means of lugs (A) utilising M6 screws.</p> <p> NOTE: The cylinder can be mounted in any of the following positions:</p> <ul style="list-style-type: none"> • horizontal; • vertical; • angled. 	 <p style="text-align: center;">Fig. 1 Cylinder mounting</p>
2	<p>Install the flow reducer valve as shown in figure 2.</p> <p> CAUTION The direction of installation must be as shown with OK in the figure, otherwise the device will malfunction.</p>	 <p style="text-align: center;">Fig. 2 Flow reducer valve installation (without QVV)</p>
3	<p>When envisaged, install the QVV (optional) as shown in figure 3.</p> <p> CAUTION The assembly sequence must be as shown with OK in the figure, otherwise the device will malfunction.</p>	 <p style="text-align: center;">Fig. 3 Installation with QVV</p>
4	<p>Connect the 1.5 m cable to connector (C), which protrudes from the top cap of the cylinder. Now connect the cable to the specific output (AUTOSTART) of the automatic detachment control panel.</p>	

5 MAINTENANCE

5.1 Introduction

Model DVC 100 AS does not have any special scheduled maintenance requirements. However, if the cylinder piston movements show signs of stiffening or sticking, proceed as follows.

5.2 Piston not sliding freely in cylinder

In the event of stiffness or sticking of piston movements caused by the build up of debris in the cylinder:

1. Remove the lower end cap and dismantle the piston assembly:
2. Clean the piston seal thoroughly:
3. Lubricate the seal with silicone spray.



CAUTION

Do not use lubricants other than silicone spray or the system may be damaged.







6 PRECAUTIONS FOR USE

The following text describes important information and precautions to be observed in relation to specific components of the equipment.



WARNING

Failure to comply with the information given in this manual can lead to malfunctions of the equipment or damage to the system.

Component	Precaution
Washing	 CAUTION Make sure the piston (ref. 028) is at the end of its run near the lower cap during washing to prevent permanent seal distortion which could cause leaking
Versions without Safety clip	 CAUTION The lower cap (ref. 029) on the DVC 800 is secured to the cylinder body with a bayonet connection; it is possible that all the versions without the Safety clip (ref. 031 that forms the safety device) may be subject to rupture should the animal drag the unit with it.
Cord	<ul style="list-style-type: none"> • The cord must always be free running to enable correct release and detachment of the cluster. • If the system is equipped with positioning arms, the cord must anyway remain free running. • For correct operation of the Autostart system the rope must be taut in detachment conditions  CAUTION Ensure the cord does not rub against any live edges or abrasive surfaces during its movement
If pulleys are installed	In the presence of external relay pulleys (solution adopted in cabin type and rotary systems) fit pulleys to ensure the cord is correctly guided and always ensure that the pulleys are well lubricated and in good condition.  CAUTION Use no more than 2 external pulleys
Bushes	 CAUTION The installation on the cylinder of external bushes should be avoided if possible; if unavoidable, use no more than 1 bush per milking stall and ensure that it is always well lubricated.
Cable connected to upper cylinder cap	 CAUTION The cable exiting from the upper cylinder cap should not be bent to a tight angle or damage to the system may result.
ACR Panel	 CAUTION If the ACR panel is fitted directly onto the cylinder, make sure the straps FASTENING do not distort the internal part of the cylinder.

7 TROUBLESHOOTING

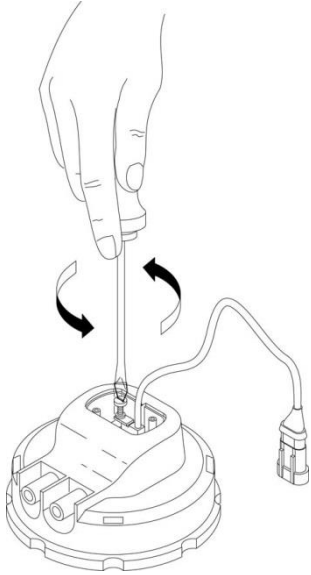
Problem	Solution
Autostart function fails to run	<p>If the Autostart function fails to function when the milking cluster is lifted in the detachment step, make the following adjustment:</p> <ol style="list-style-type: none">1. Remove the cover of the cylinder upper cap to gain access to the sensor distance adjuster screw as shown in figure 4.2. Turn the screw COUNTER-CLOCKWISE one step at a time, 2 revolutions at each adjustment. <p>! CAUTION Do not completely undo the adjuster screw: the adjuster screw must be present because it operates as a stop for the sensor.</p> <ol style="list-style-type: none">3. Re-close the cover and tighten the screws manually with a screwdriver. <p>! CAUTION Always tighten the 2 upper cap cover fixing screws</p> <ol style="list-style-type: none">4. Repeat the activation test.  <p>Fig. 4 – Reduce distance between sensor and magnet (turn counter-clockwise).</p>

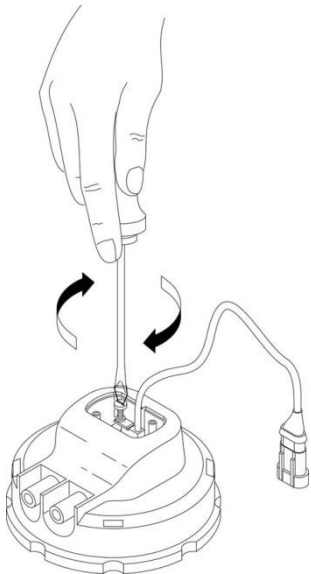
Problem	Solution
<p>Nuisance reactivation of Autostart function</p>	<p>If the Autostart function trips when it is not required when the cluster is removed, make the following adjustment:</p> <ol style="list-style-type: none"> 1. Check that the manifold breather hole is not clogged. If it is clogged, free it to prevent the cluster from ascending suddenly during the detachment stage. 2. Check whether the delay between closing of the shut off valve and removal of the cylinder is sufficient to allow the milking cluster to ascend, because the faster the ascent speed the greater the risk of undesired activation (this delay, if it can be set on the panel, must be set to the maximum possible value, without resulting in the problem of falling of the clusters). <p>If the problem persists make the following adjustment in the detachment stage:</p> <ol style="list-style-type: none"> 3. Remove the cover of the upper cylinder upper cap to gain access to the sensor distance adjuster screw as shown in figure 5. 4. Turn the screw CLOCKWISE one step at a time, 2 revolutions at each adjustment. <p>! CAUTION Do not completely undo the adjuster screw: the adjuster screw must be present because it operates as a stop for the sensor.</p> <ol style="list-style-type: none"> 5. Re-close the cover, tightening the screws manually with a screwdriver. <p>! CAUTION Always tighten the 2 upper cap cover fixing screws</p> <ol style="list-style-type: none"> 6. Repeat the activation test.  <p>The diagram shows a hand using a screwdriver to turn a screw clockwise. The screw is located inside a circular component, likely the upper cylinder cap. A cable is connected to the component. Two curved arrows indicate the clockwise direction of rotation.</p> <p>Fig. 5 – Increase distance between sensor and magnet (turn clockwise).</p>

Problem	Solution
Leaks or piston movement problems	<p>In the event of leaks or stiffness or sticking of piston movements caused by the build up of dirt sediment in the cylinder:</p> <ol style="list-style-type: none">1. Check that the hose supplying vacuum to the cylinder is not restricted or kinked.2. Remove the lower end cap and dismantle the piston assembly:3. Clean the piston seal thoroughly.4. Lubricate the seal and cylinder internal chamber with silicone spray. <p> CAUTION Do not use lubricants other than silicone spray or the system may be damaged.</p> <ol style="list-style-type: none">5. If the problem persists, renew the seal.

8 EXPLODED DRAWING

